

TECHNICAL MANUAL

Nita Satellite NS-10-50 for 1 Chemical

Item-Nr. 21-1706

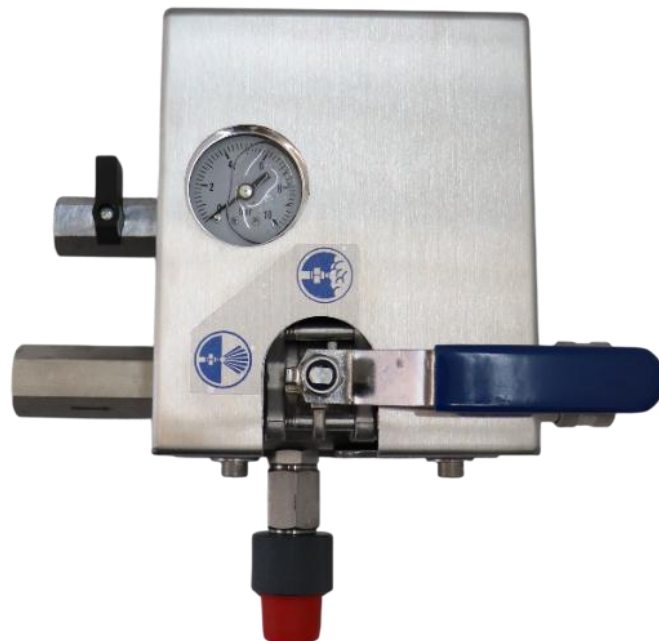

Issue 04.2026

GENERAL INFORMATION

The Nita Satellite NS-10-50 uses pressurized water from a medium-pressure system and is connected to the compressed air line.

The chemical is drawn from a canister located below the satellite and mixed into the water through a dosing nozzle.

Using one hose and a lever, the operator can perform a complete OPC cleaning program:

- Pre-rinsing
- Foaming
- Intermediate rinsing
- Disinfection
- Final rinsing

SAFETY PRECAUTIONS

CAUTION! - SYSTEM CONTAINS CHEMICALS

Make sure that accessories or hoses are flushed before any repairs if concentrated chemicals have been used! Before every repair, all accessories must be flushed with clean water. Let the device run until all chemicals have been completely flushed out of the system.

CAUTION! - HAZARDOUS SUBSTANCES

Contact with chemicals can be fatal and may cause severe injuries or illnesses.

Always read and follow the manufacturer's or supplier's Safety Data Sheet when handling chemicals.

Make sure that

- the Safety Data Sheet is available,
- an emergency shower is installed,
- a portable or wall-mounted eyewash station is available and ready for use, and
- additional washing facilities are located nearby.



INSTALLATION

Mount the unit on the wall in a suitable location using 2 screws $\text{Ø}6 \times 60$.

Connect the water supply to the water inlet **[A]**.

Connect the air supply to **[B]**.

Connect the working hose to **[C]**.

Insert the suction tube **[D]** into the chemical container.

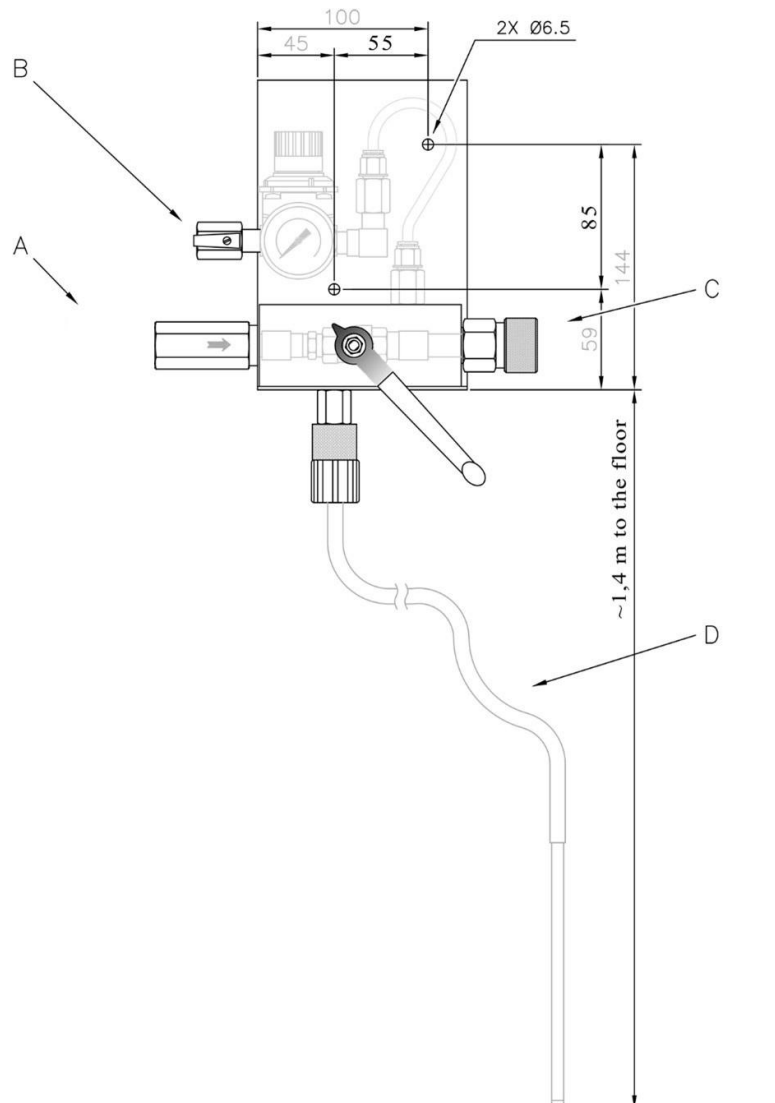

OPERATION

The density of the foam can be adjusted with the regulating valve **[E]**. The air pressure is indicated at the pressure gauge **[G]**.

The chemical concentration/consumption can be adjusted by changing the dozing nozzle at **[P]**.

Changing between Flush and Foam/Disinfection is done by the valve **[J]**.

Changing between Foam and Disinfection is done by the valve **[C]**.

After each chemical cleaning process, the chemical suction tube should be placed in a container with clean tap water. Set the lever to **Foam** and allow the system to run with sufficient clean water. Flushing the system reduces the risk of crystallized chemical residues in the pipes and nozzles. Such residues can cause blockages and significantly impair the system's functionality.

The following figure illustrates the chemical concentration achievable by changing the colour coded dozing nozzles.

Dozing nozzle [colour]	Approx. Chemical concentration [Pct]
White	1%
Red	2%
Blue	3%
Black	4%
Orange	5%
Grey	6%

NOTE! The exact percentage depends on the viscosity of the chemistry used, temperature and the suction height. Calibration is necessary if very accurate figures are required.

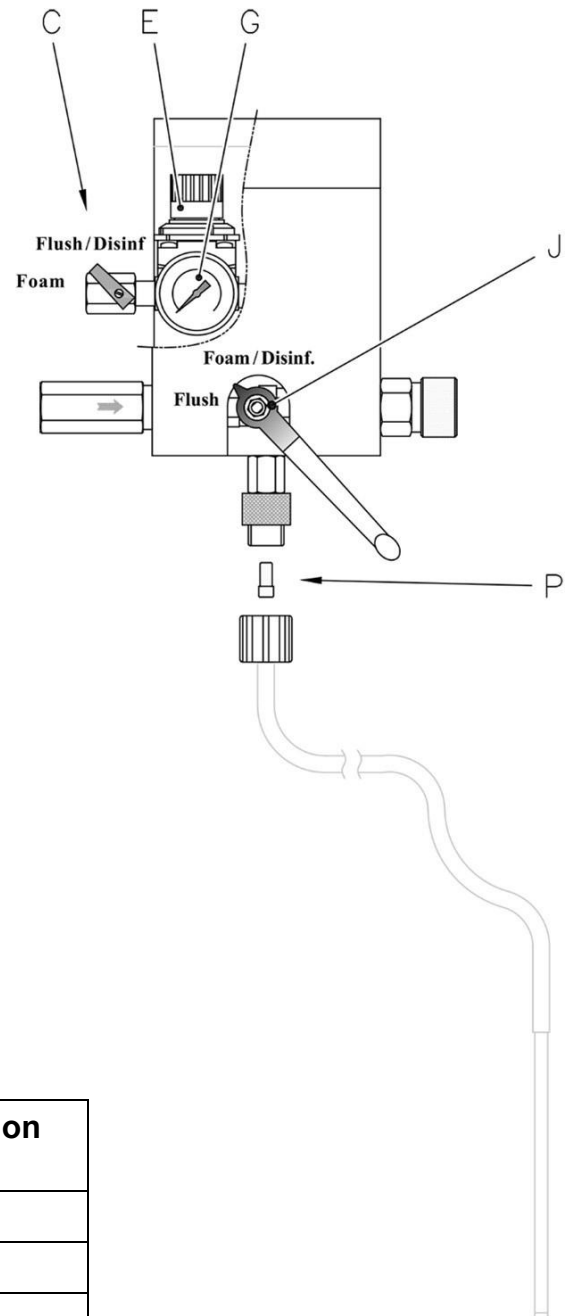

TROUBLESHOOTING GUIDE

Satellite does not operate

- Is water / pressure available?
- Is the spray gun damaged?

Pulsating water during rinsing

- Is the water temperature above 70°C?
- Is too much water being drawn elsewhere?
- Ensure the correct spray lance is being used.

Foam is not forming properly / foam is too wet

- Check that the air supply is sufficient and switched on.
- Increase the air pressure.
- Increase the chemical concentration by replacing the colored suction nozzle.
- Is the suction nozzle clogged?

Nozzle spits

- Is the chemical container empty?
- Is the suction tube inserted into the product container?
- Is the filter in the suction tube clogged?
- Is the suction nozzle clogged?

Foam is too dry

- Reduce the air pressure.
- Reduce the chemical concentration by replacing the colored suction nozzle.

Water consumption is too high

- Check that the correct spray lance is being used.
- Check if the spray nozzle is damaged or removed.

MAINTENANCE INSTRUCTIONS

We recommend maintenance of the foam satellite **every six months or annually**, depending on usage frequency.

- 1) **Set the lever (A) to the foam position – pointing downward**
- 2) **Loosen the side screws (B) and remove the housing cover**

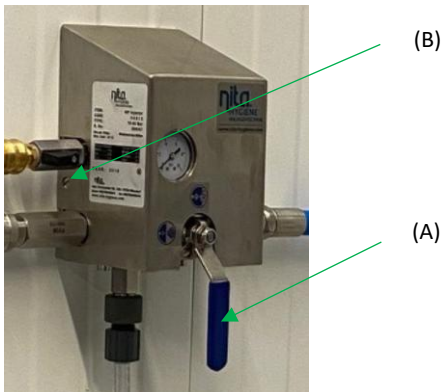

3) **Function test: Chemical non-return valve (Pos. 22 – Figure 1)**

- Disconnect the suction hose (Pos. 26 – Figure 1) from the lower inlet of the satellite
 - Connect the working hose including the spray gun to the outlet
 - Open the water supply – do not operate the spray gun!
- Check the chemical non-return valve function:
 No water flows → non-return valve OK
 Water flows → non-return valve defective

4) **Function test: Compressed air non-return valve (Pos. 8 – Figure 1)**

- Disconnect the blue compressed air hose (Pos. 7 – Figure 1)
- Open the water supply – do not operate the spray gun!
- Check the compressed air non-return valve function:
 No water flows → non-return valve OK
 Air escapes → non-return valve defective

5) **Function test: Water inlet non-return valve (Pos. 16 – Figure 1)**

- Disconnect the water supply to the satellite
 - Keep the working hose and spray gun connected
 - Open the ball valve at the compressed air inlet of the satellite (Pos. 1 – Figure 1)
- Check the water inlet non-return valve function:
 No air escapes → non-return valve OK
 Water flows → non-return valve defective

6) Cleaning the Injector Nozzles

- Disconnect the water supply to the satellite
- Remove the working hose and spray gun
- Remove the non-return valve at the inlet (Pos. 16 – Figure 1) and the quick coupling at the outlet (Pos. 11 – Figure 1).
- Disconnect the compressed air non-return valve (Pos. 8 – Figure 1), including the double nipple
- Unscrew the air injector nozzle (Pos. 7 – Figure 2)
- Disconnect the chemical non-return valve (Pos. 22 – Figure 1), including the double nipple
- Unscrew the 2 hex screws below the injector block on the mounting bracket and remove the injector
- Using a circlip plier (Nita part no.: 92-18717), remove the 2 circlips (Pos. 2 – Figure 2)
- Screw a standard M6x50 machine screw into both ends of the injector nozzles (Pos. 4 + 5 – Figure 2) and pull the nozzles out
- Clean or replace the nozzles
- Replace the 2 O-rings of the nozzles (Pos. 3 – Figure 2) and lightly grease them externally
- Reinstall the nozzles into the injector using the machine screw
- Use circlip pliers to install new circlips
- Replace the O-ring of the air injector nozzle (Pos. 6 – Figure 2)
- Screw the air injector nozzle back in (**CAUTION:** ensure the bore is aligned – the outlet hole must point in the flow direction)
- Replace the O-rings of the double nipples at the air and chemical inlets (2 each, Pos. 20 – Figure 1) and install them with the non-return valves on the injector
- Replace the O-rings at the water inlet non-return valve and at the double nipple at the satellite outlet (Pos. 15 – Figure 1) and reassemble the parts
- Install the dosing nozzle for the desired concentration from the dosing nozzle set (Pos. 25 – Figure 1) and attach the suction hose
- Perform a function test
- Reattach the housing cover and tighten the side screws

Suggestion:

Replace all non-return valves once a year. Replace dosing nozzles during every maintenance.

Spare parts recommendation for maintenance:

Part-Nr.	Description	Quantity
52-1844	Compressed air non-return valve	1x
52-1845	Water inlet non-return valve	1x
52-1843	Chemical non-return valve	1x
64-1846	Dosing nozzle set 1–6%	1x
60-01881	O-ring for air and chemical inlet	5x
60-01882	O-ring for air injector screw	1x
60-01883	O-ring for water inlet & outlet	2x

TECHNICAL SPECIFICATIONS

Min. water inlet pressure	10 bar
Max. water inlet pressure	50 bar
Max. water temperature	70 °C
Flow rate max.	60 l/min
Standard water flow	30 l/min
Flow rate (foam)	10 l/min
Flow rate (disinfection)	10 l/min
Water inlet	½" female thread
Min. air inlet pressure	5 bar
Max. air inlet pressure	10 bar
Air flow (at 6 bar)	150 l/min
Air inlet (ball valve)	¼" female thread
Air pressure gauge	incl.
Dosing range	1-6 %
Chemical inlets	1
Suction hose	incl.
Dosing nozzles	incl. (1-6%)
Weight	4,6 kg
Outlet	Quick coupling

Safety Features:

- 1x non-return valve on the water inlet side
- 1x non-return valve on the chemical inlet side
- 2x non-return valves on the compressed air side
- 1x suction filter on the suction tube

SPARE PARTS

Figure 1

Pos.	Item no.	Description
1	52-38251	Ball valve, brass
2	53-08253	Pressure gauge ø40, 10 bar. Incl. back connection
3	53-08252	Air regulating valve
4	52-1839	Non-return valve, stainless steel
5	52-28254	Elbow fitting
6	53-28101	Push in fitting, Elbow
1-6	64-1884	Air inlet, complete
7	12-01885	Air hose
8	52-1844	Non-return valve, 1/4", EPDM
10	64-1874-M50	Complete injector, Standard
11	64-1008	Quick coupling, complete
12	60-01883	O-Ring, water
13	64-18255	Bypass valve, complete
15	60-01883	O-Ring, water
16	52-1845	Non-Return valve, Standard
20	60-01881	O-Ring, chemical
21	50-06461	Hex nipple
22	52-1843	Non-return valve, stainless steel, 1/4"
24	64-1847	Holder for dosing nozzle
25	64-1846	Dosing nozzle set, 1-6%
25.1	64-1892-1	1% White
25.2	64-1892-2	2% Red
25.3	64-1892-3	3% Blue
25.4	64-1892-4	4% Black
25.5	64-1892-5	5% Orange
25.6	64-1892-6	6% Grey
26	27-1848	Suction tube, complete
26.1	52-01854	Chemical filter, stainless steel
26.2	12-08021	Hose
26.3	61-02006	Dosing nozzle screw-on sleeve

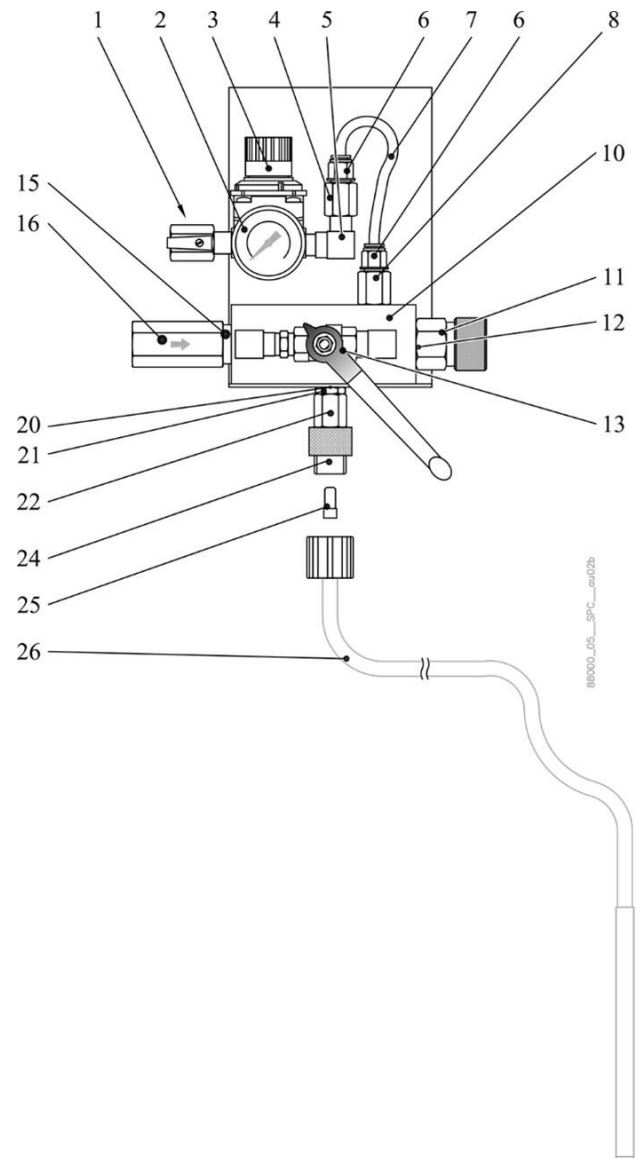
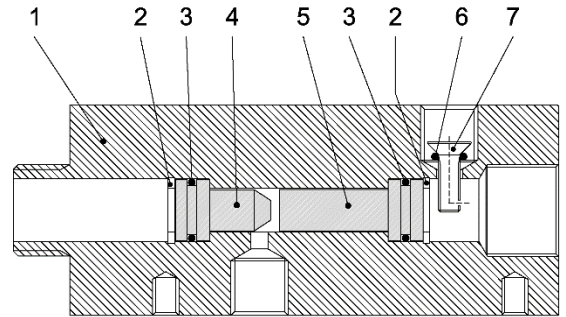

Figure 2 (Complete Injector Item-Nr. 64-1874-M50)

Pos.	Item no.	Description
1	64-1760	Injector body
2	60-21880	Circlip
3	60-01881	O-ring for injector nozzles
4	64-187518	Injector inlet nozzle
5	64-187826	Injector outlet nozzle
6	60-01882	O-ring
7	64-1763	Air nozzle. Note! Outlet hole must point in the flow direction.
8	92-18717	Tool for circlip



Pos. 8 Tool for circlip

Use a long (>70mm) standard screw with M6 thread to pull out the nozzles.

DECLARATION OF CONFORMITY

Name and address of the manufacturer:

ScanFoam Cleaning Equipment ApS

Niels Bohrs Vej 29B

8660 Skanderborg

Denmark



This declaration is issued under the sole responsibility of the manufacturer.

Object of the declaration:

21-1706

The object of the declaration described above is in conformity with the relevant Union harmonization legislation:

2006/42/EC

References to relevant harmonized standards used or references to the other technical specifications in relation to which conformity is declared:

EN ISO 12100:2010

EN 1672-2:2020

Additional information:

Person authorized to compile the technical file (2006/42/EC): Barry Fulcher

Manufacturer (see above)

Signed for and on behalf of the above-named manufacturer:

Place and date of issue: Skanderborg, Denmark

2025-06-11

Name, function: Barry Fulcher

Managing Director

Signature:



/ EN

The English version of this document is the original version.

All other languages are translations of the original version.